

In Touch

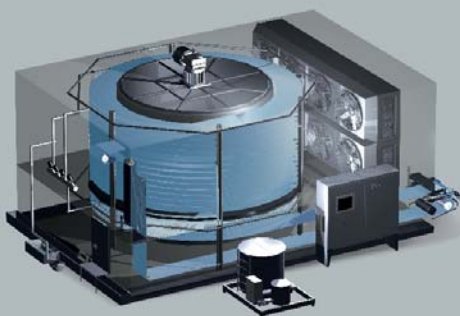

Aerofreeze spiral freezers and chillers

In touch with GEA Freezing—
hygienic food processing

GEA Refrigeration Technologies through the GEA Freezing product range represents innovative solutions in industrial freezing and chilling closely oriented to the stringent requirements of its customers: Cost-efficient, long-life, energy-efficient and customized.

° In touch with your processes: optimum freezing and chilling solutions

Extensive experience in freezing and chilling food processing

Ready-meals, pizzas, shrimp, fish, hamburger patties, meatballs, sausages, chicken wings, chicken fillets, chicken nuggets, bread, sponge cakes, muffins, cookies, etc. etc. Raw, par-fried, par-baked or fully cooked products: With the rapid change in the market demands and innovations in food processing, there have been many product developments requiring unique handling. GEA experts in frozen food applications ensure that the best solution is identified for your product.

Aerofreeze spiral freezers and chillers are designed for hygiene, high-efficiency and reliability.

We guarantee quality and safe products throughout your entire freezing or chilling process. How? Based on our proven know-how with regard to food freezing and chilling, together with the ability to test your products in our technology center, we select and test the optimum freezing or chilling configuration for your specific application.

Innovative, optimized, scientifically proven

Our R&D department uses the latest airflow and heat transfer technologies. With the ability to conduct simulations and confirm the results in our test freezers, we can quickly generate new and industry-leading solutions that energy efficiently maximizes product quality and yield.

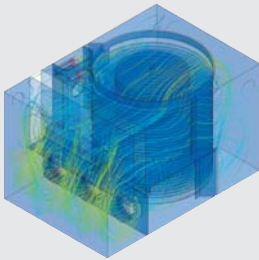
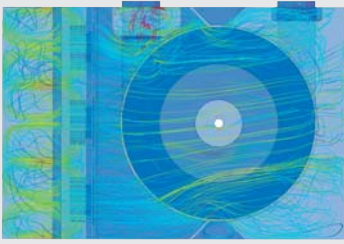

In GEA Tech Center, 3D model simulations are built to optimize airflow and heat transfer for all spiral series.

GEA Freezing manufacturing facility.

Evaporators, enclosures, floors, frameworks and control panels are manufactured and assembled in our 10,000m² plant.

° Designed for hygiene and increased reliability

Aerofreeze spiral freezers and chillers

Capable of handling capacities from 0.2 to 7 tons per hour, the Aerofreeze spiral freezers are designed by expert engineers to exact specifications based on your product characteristics, capacities, facility space and line layout.

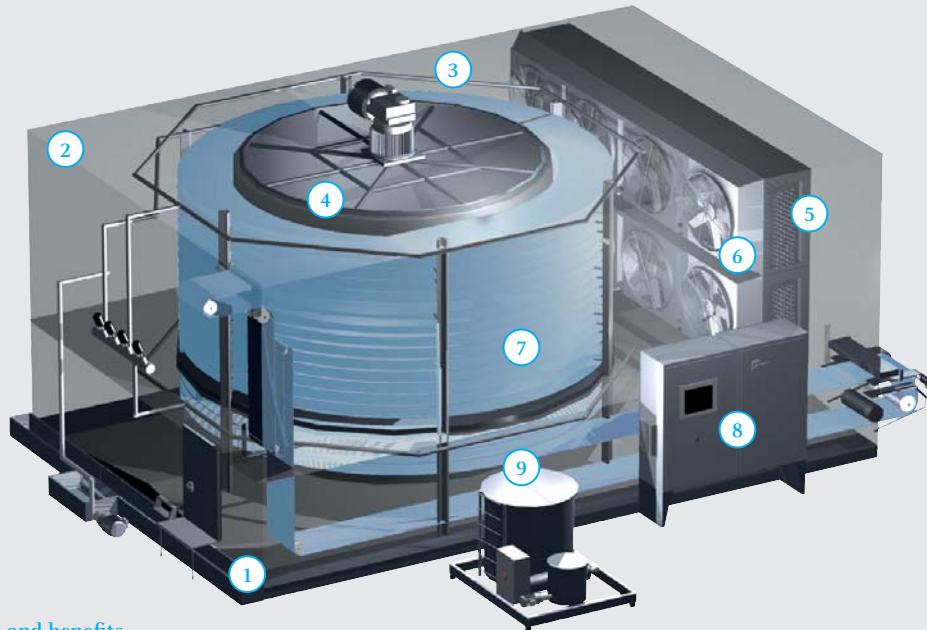

Features and benefits

- 1 Floor design:** All-welded, insulated and sloped. Does not require heating.
- 2 Enclosure:** Fully stainless steel. Long-lasting equipment, smooth surfaces for ease of cleaning.
- 3 Top drive:** Uniquely sits outside the enclosure for easy maintenance.
- 4 Profiles:** Non-hollow. The structure standing on elevated studs welded on the floor eliminates dirt traps.
- 5 Evaporators:** Use stainless steel tubes with high-efficiency aluminum fins to optimally transfer heat.
- 6 Horizontal airflow:** Lowers energy consumption and efficiently transfers heat.
- 7 Conveyor structure:** Omits caps on belt rail and drum bars to optimize hygiene with plastic belt.
- 8 Operator interface:** Smart and intuitive with touch screen offering data recording and remote control options.
- 9 Recirculating CIP system:** Only uses half as much water as non-circulating systems.

Customized to specifications

Aerofreeze spiral freezers will:

- ° Meet your product handling, facility and freezing and chilling-application requirements
- ° Handle 1 shift-14 days of operation without stopping to defrost, based on the evaporator configuration we select for your needs – whether Sequential Defrost (SD) or Snow Removal System (SRS)

Cost-efficient production

Our spiral freezers profitably:

- ° Save energy and minimize yield loss by optimizing airflow
- ° Reduce cleaning cycles through ultra-hygienic design – designed to be cleaned with a CIP (Clean-In-Place) system

Great durability

Our spiral freezers are strengthened by:

- ° Fully welded stainless steel
- ° Customer support and easy maintenance

° In touch with your operations: Installation to implementation

Compact and modular spiral freezers and chillers

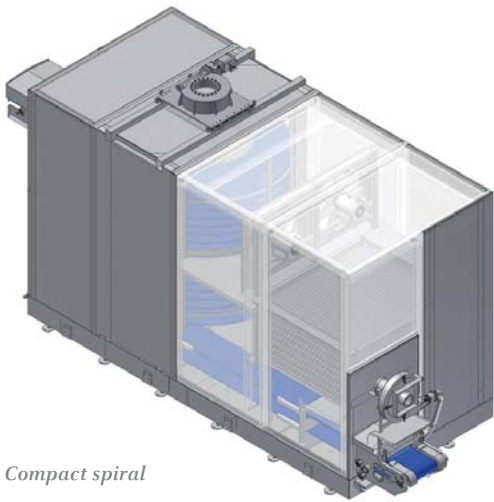

Compact spiral

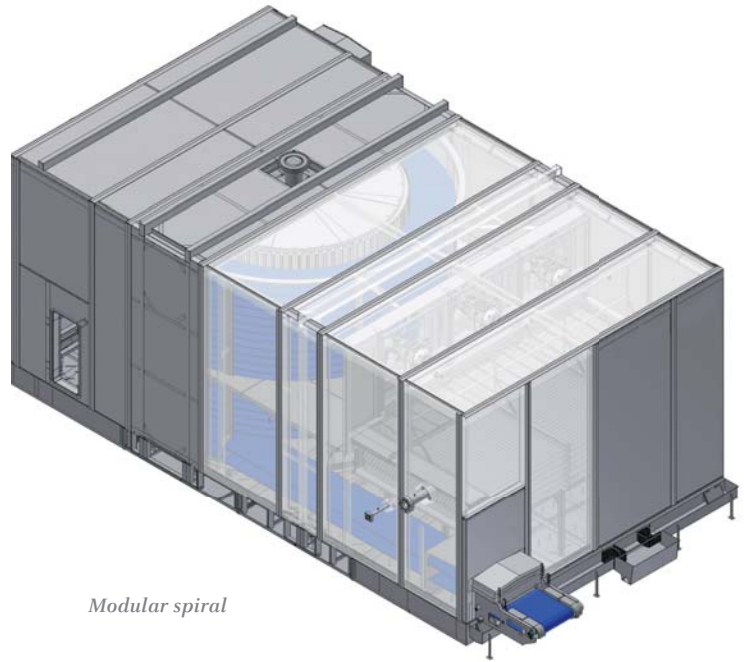

Modular spiral

Aerofreeze spiral freezers and chillers are specifically designed for:



Easy, short installation

- ° Compact spirals are fully prefabricated prior to shipping



Hygiene

- ° Modular, fully integrated insulated, sloped floor
- ° Insulated enclosure—fully welded both inside and outside

Easy cleaning

- ° All components are easily accessible
- ° Internal staircase for easy and safe access
- ° Designed and built to be cleaned

Aerofreeze compact spiral freezers

Typical application	Dimensions (inch)	Imperial		Dimensions (mm)	SI	
		Weight (oz)	Capacity (lb/h)		Weight (g)	Capacity (kg/h)
Fish		L x W x H		L x W x H		
Fish filets, raw	8" x 3.5" x 0.5"	4	1,050	200 x 90 x 13	113.5	475
Fish finger, battered and breaded, par-fried	4" x 1.25" x 0.6"	1	1,610	100 x 32 x 15	28.5	730
Fish filets, battered and breaded, par-fried	5.25" x 4" x 0.7"	6.6	760	130 x 102 x 18	187	345
Meat						
Hamburger, raw	4"(D) x 3/8"(H)	4	1,610	102(D) x 10(H)	113.5	730
Hamburger, cooked	4"(D) x 3/8"(H)	4	920	102(D) x 10(H)	113.5	420
Meat ball, raw	Sphere 1"	0.28	3,900	Sphere 25.4	8	1,780
Meat ball, cooked	Sphere 1"	0.28	3,050	Sphere 25.4	8	1,390
Poultry		L x W x H		L x W x H		
Chicken wing section, raw	3 - 3.5 lb bird	2.5	1,610	1.4 - 1.6 kg bird	71	730
Chicken tender, raw ¹⁾	4" x 1" x 0.5"	1	1,610	102 x 25 x 13	28.5	730
Chicken filets, raw ¹⁾	1.5" x 1" x 0.5"	4	1,610	38 x 25 x 13	113.5	730
Chicken nuggets, par-fried	5.5" x 3.5" x 0.75"	4	980	140 x 90 x 19	28.5	530
Chicken filets, battered and breaded, par-fried	5.5" x 3.5" x 0.75"	4	1,160	140 x 90 x 19	113.5	445
Chicken tender, par-fried	4" x 1" x 0.5"	1	1,440	102 x 25 x 13	28.5	660
Chicken nuggets, full-cooked	1.5" x 1" x 0.5"	1	980	38 x 25 x 13	28.5	445

¹⁾ The vacuum marinated chicken filets and tenders need to be crusted on the bottom surface before being fed into the freezer.

Shipping data ²⁾	Imperial	SI
Shipping dimensions (L x W x H)	23'9" x 7'10" x 11'10"	7.24 x 2.39 x 3.61 m
Shipping weight	30,500 lb	13,860 kg
Flat rack requirement	1 x 40'	1 x 40'

²⁾ Easy installation: Aerofreeze compact spiral freezers are fully prefabricated prior to shipping.

Aerofreeze modular spiral freezers ³⁾

Product ⁴⁾	Capacity
Meat, Poultry, Fish, Pizza, Ready-made meals, ...	up to 7 tons/hour

³⁾ Each model is optimized to meet your individual application and site condition. ⁴⁾ Other products: Please contact us.

° In touch with your application: Tailor-made solutions

Flexible equipment options

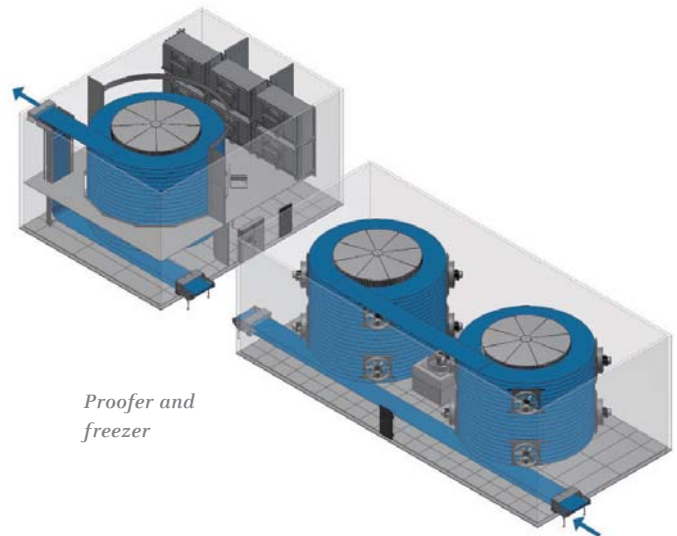
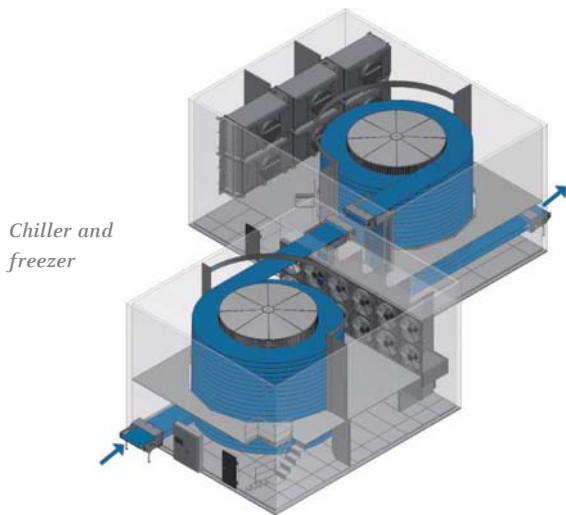
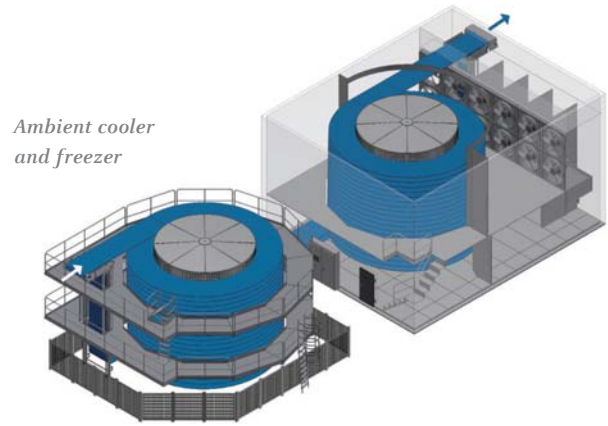
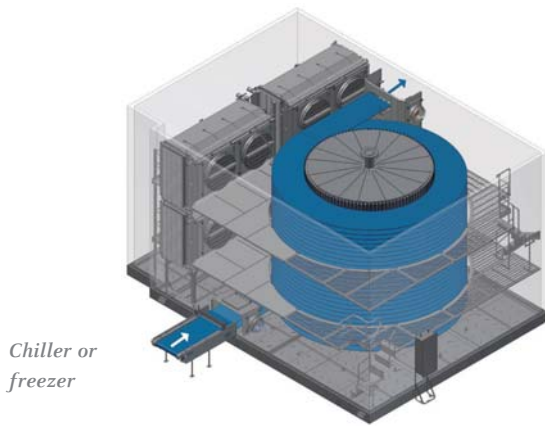

° Integration in your processing line

Process flow design

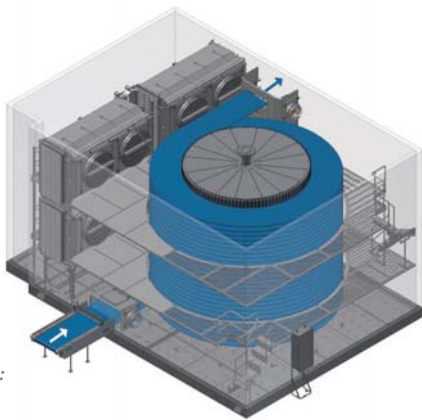

Single drum:
up-cage

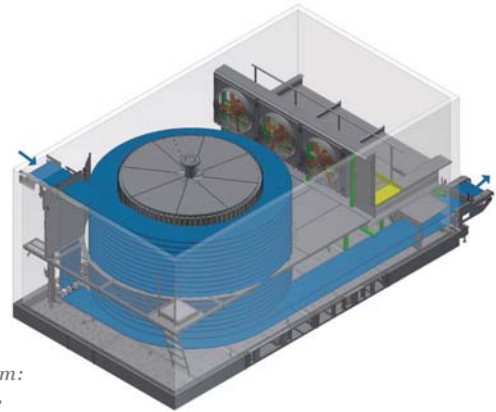

Single drum:
down-cage

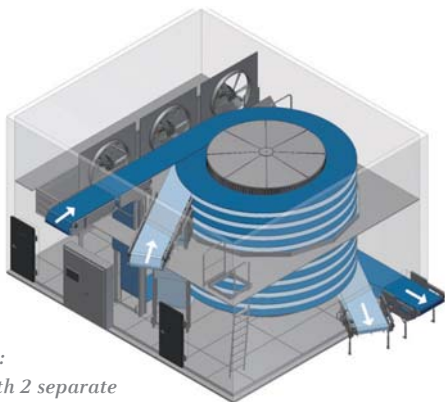

Single drum:
twin-belt with 2 separate
in-feed lines

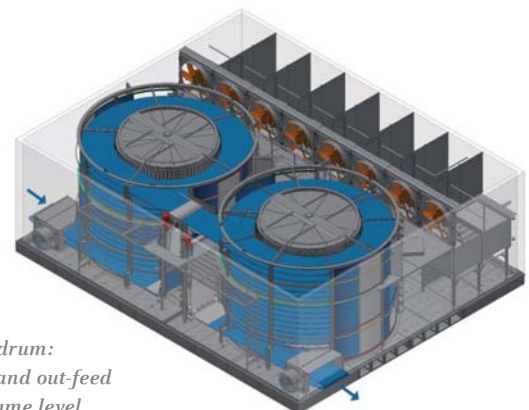

Double drum:
in-feed and out-feed
at the same level

° Customized configuration

Flexible belt options

Further, we can configure your belt options to flexibly turn clockwise or counterclockwise—based on your specific needs.

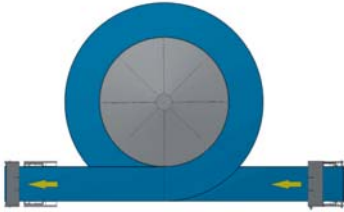

Straight-through

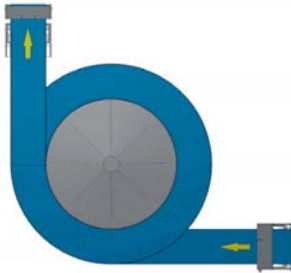

90° turn

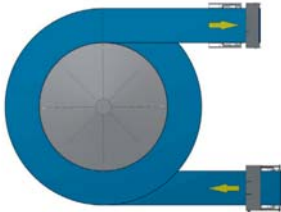

180° turn

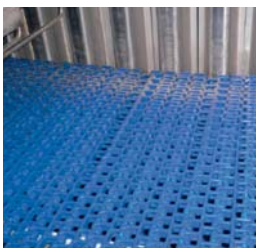

Plastic:
Acetal/Polypropylene



Stainless steel

Application-specific belt selection

° In touch with stringent cleaning requirements

Comprehensive cleaning with minimal labor



Rotating nozzle



Recirculating Clean-In-Place (CIP) system

Recirculating CIP system

We developed the recirculating Clean-In-Place (CIP) system alongside experienced food processing experts to satisfy industry requirements.

Similar to a dishwasher, the system circulates volumes of water to effectively wash your freezer. The system also provides the option of repeating a sequence to intensify cleaning if you are running products with heavy coating. These capabilities reduce water consumption compared to manually washing your equipment and traditional foaming systems that typically require you to repeat the entire cycle for additional cleaning. To ensure reliable operation, we designed the system with self-cleaning spinners and several filters that operate sequentially throughout the cycle.

°In touch with hygiene

Your main concern. Our guarantee



GEA Aerofreeze freezers and chillers satisfy the food industry's most stringent hygiene requirements through their:

Hygienic by design

Built with fully welded stainless steel, including the floor and enclosure. The smooth surface is easy to clean.



Structural support

Built with all-welded stainless steel. Prevents dirt, water and soil from remaining on the surface.

Good drainability

Consistent sloped floor drains easily. The structure sits on elevated studs welded to the floor eliminates dirt traps.



Insulation without caulked joints

Option for fully welded insulated panels and floor on all our tunnels.

Recirculating CIP system

Foaming Clean-In-Place (CIP) covers some or all zones. The recirculating CIP system pumps and filters water, acting like a giant dishwasher – using less water and detergent than non-circulating systems.



GEA Refrigeration Technologies offers superior customer support services. These services add significant value to your company's operation. Staffed by well-trained and experienced technicians, your experience with our service and support will be a positive one.

° In touch with our customers

We offer you: top competence, from development to service



Worldwide service support

Of course we won't leave you alone when your systems have been installed. We support you during your plant operation, assure optimal maintenance, supply wear and spare parts, and are quickly there when your refrigeration systems unexpectedly have difficulty. In short: we are responsible for absolutely satisfactory operation – with companies around the world, and with highly competent staff.



Training programs by experts

Reliable maintenance and emergency repair service

We offer you preventive and restorative maintenance. Our engineers are selected, ongoing-trained experts that stand at your side around the world, and quickly and efficiently repair your equipment, minimizing production downtime. We customize your contract to meet your needs, from annual audits to full maintenance. You can depend also on our expert knowledge if you are looking for new possibilities of efficiency enhancement. Either for purchase or as part of contracting: our team will find for you the energy-optimized and sustainable solution.

Proven spare parts

GEA Refrigeration Technologies quotes, designs and provides genuine replacement parts to optimize the performance and extend the operational life of your freezer or chiller. Owing our manufacturing shop, we can quickly manufacture your replacement parts, customizing them to fit your unique installation – without delay.

Friendly expert training

GEA Refrigeration Technologies offers training programs designed to optimize the performance of your freezer or chiller. Our highly skilled engineers conduct these programs for existing or new employees at your facility or in our Technology Center.

*Please get in touch with us:
GEA Refrigeration Technologies and its companies are
located worldwide. Our complete addresses are available
on the Internet under www.gearefrigeration.com*



GEA Refrigeration Technologies
www.gearefrigeration.com